

HP Designjet 9000s Printer



Create long-lasting outdoor signage with the fastest printer in its class¹. This 64-inch HP Designjet is an excellent tool to boost production and profitability: increase your print volume, improve your services, and reduce your costs.

The HP Designjet 9000s is the ideal large-format printer for digital print shops and signmakers with mid-volume printing needs that are looking for high speed, high productivity devices to greatly reduce the production cost for outdoor applications including signs, banners, vehicle graphics, and more.

Dramatically reduce your response times and increase your print capacity.

- Get high speed printing with 6 heavy-duty piezo printheads that come with 512 nozzles per head.
- High capacity 1,000 ml, HP 790 ink cartridges mean fewer interruptions and “hot-swap” functionality lets you change a cartridge while printing.
- Improve productivity with long, unattended print runs enabled by the HP Take-Up Reel.
- Dry signs quickly and safely with the easy-to-operate HP Designjet High Speed Dryer².
- Impress customers with fast turnaround at 20.4 m²/h with four passes.

Delight customers with spectacular, durable signs and banners.

- Create an impact with vivid colours, dense black and saturated red for bold images enabled by 720 x 720 dpi.
- HP low-solvent inks produce durable prints that resist fading for 3 years without lamination³ and are scratch, smear, and crack resistant.
- Enjoy excellent durability on low-cost, uncoated media and exceptional performance and high opacity on HP printing materials: HP Premium Scrim Banner, HP Premium Self-adhesive Vinyl and HP Premium Backlit Film, designed with HP low-solvent inks.

A secure investment that is better for business with low operation costs and safe, easy printing.

- Keep costs down and still get great looking, long lasting output on uncoated media.
- Increase profits: high print speeds and low printing costs increase the break-even point against screen printers, making it easier to compete for shorter run lengths.
- Work confidently in a clean, safe print environment with an integrated air purifier⁴ created for HP Designjets and among the best on the market.
- HP’s installation and use guidelines help make HP low-solvent ink printing safe, productive, and easy.

¹ Compared to other large-format printers within the same price range. Based on the recognised standard printing mode in the digital print industry: 720 dpi with four passes per colour, published by manufacturers as of November 2005.

² The dryer is available as an optional (not included, sold separately) accessory with the HP Designjet 9000s printer. A dryer is required when printing at high speeds and using the automatic take-up reel to roll up output, and when prints need to be manipulated immediately. This dryer requires a 230v circuit.

³ Based on internal HP testing under specific test conditions and relative to key competitors.

⁴ The HP Designjet Air Purifier System is available as an optional (not included, sold separately) accessory with the HP Designjet 9000s Printer.

HP Designjet 9000s Printer

1. 16.35 m² per hour at 720 x 720 dpi with four passes. 20.4 m² per hour at 540 x 720 dpi with four passes
2. Up to 1,626 mm media width
3. Six 1,000 ml, HP 790 ink cartridges with "hot-swap", which allows you to change an ink cartridge without interrupting the print job
4. Heavy-duty HP Take-Up Reel with four winding modes
5. Interactive front panel
6. USB 2.0 Hi-speed connectivity
7. 3 user-controllable integrated heaters
8. Easy media-loading
9. Exhaust attachment for efficient removal of volatile organic components
10. Printhead height adjustable to 2 different positions
11. Adjustable vacuum system to match media width

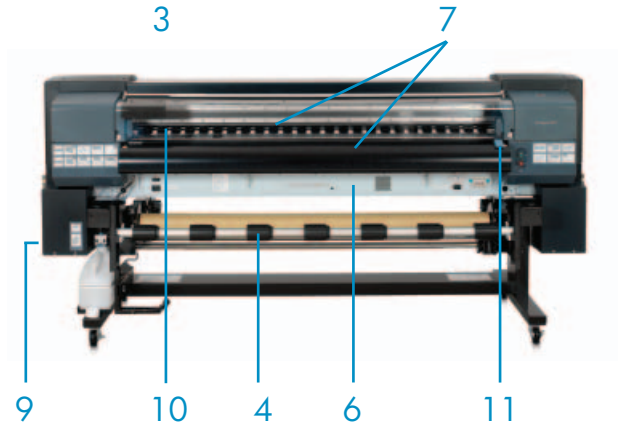
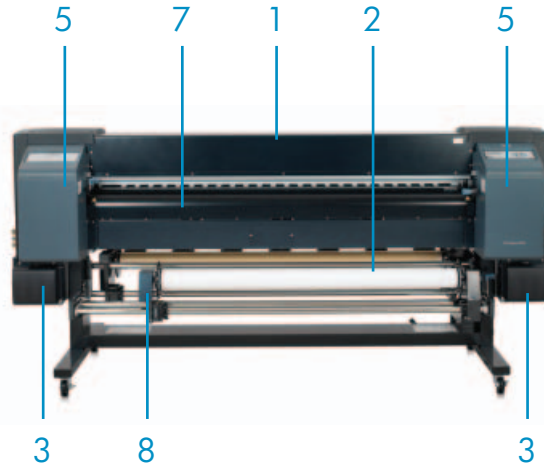

The HP Designjet 9000s Printer, HP low-solvent ink formulations, ink cartridges, and printing material were all designed, engineered and tested together to ensure uncompromising reliability, image quality, durability, performance and ease of use. To complete the total printing solution, HP offers the following accessories:

HP Designjet Air Purifier System

Put your confidence in HP. Add this air purifier system – specially designed for HP low-solvent inks – to your HP Designjet printer for highly efficient air filtration.



Count on HP for a clean, safe¹ print environment

- **Highly effective carbon filter removes hazardous substances released from solvent inks**

The air purifier system developed for the HP Designjet 9000s Printer series uses carbon filters to extract from the air volatile organic compounds released during the printing process. The system is designed to filter air at rates consistent with the print speed and the number of compounds released during printing.



¹ When used appropriately, according to the product's guidelines.

² A take-up reel comes standard with HP Designjet 9000s Printer.

“The new HP low-solvent solution adds outdoor graphics applications to our business, greatly reducing our production costs. Only HP could give us the confidence and peace of mind to safely and successfully expand into this field”.

Arnau Sallent,
General Manager of PROPAGANDA PRINTS in Barcelona, Spain

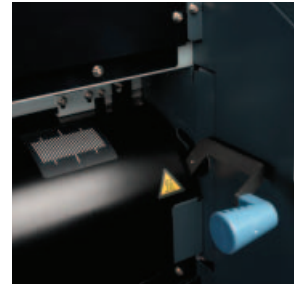
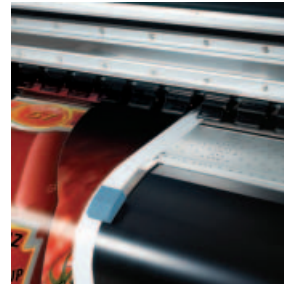

HP Designjet High Speed Dryer

Add this high-speed dryer to your HP Designjet 9000s printer and accelerate drying time. Control temperature, fan airflow, and the timer from the front panel. Count on the stable stand and heating and blowing technology for safe operation.

Improve productivity – dryer reduces drying time

- **Dry prints as quickly as the automatic take-up reel² can roll them up**

When you use the automatic take-up reel² to roll up printed output, you should also use a dryer to keep the ink from transferring from one part of the print to another or from print to print. With the high-speed dryer and take-up reel², you can complete jobs at a maximum printing speed of 29.9 m²/h. The integrated dryer and take-up reel enable unattended print runs.

- **Dryer's off timer allows unattended drying for up to 12 hours**

Dry print jobs even when you can't be there. Set the dryer's off timer from 1 to 12 hours to print unattended runs.



Onyx[®] PosterShop[®] 7.0 for HP Designjet

Use this Onyx[®] PosterShop[®] RIP to print job after job of the best colors your printer can produce. Efficiently manage jobs and handle production with job preflight and printer queue tools.

Print the colours your customers expect

- **Make colour changes – to precise spots or entire images – with intuitive colour correction tools**

Change the brightness, saturation, and contrast for the entire image, or adjust highlights, mid-tones, and shadows. Even fine-tune select areas to achieve the perfect look. All without affecting the original file.

- **Match colours as closely as possible to the Pantone Colour Library**

This RIP includes a fully licensed Pantone Colour Library, which makes spot colour matching easy because more accurate Pantone spot colour matching happens automatically during processing. The RIP recognises Pantone-named colours in PostScript or PDF files and matches the colours as closely as possible.



Print and customise jobs quickly and easily

- **Modify jobs and see final layout on your screen before printing with easy-to-use preflight controls**

Avoid unexpected and costly results at the final output stage. Use the RIP's easy-to-navigate and easy-to-use preflight controls to ensure that all the necessary components—fonts, images, colour profiles, etc. are correct and in the right location. See the final file layout on your screen before it prints. If necessary, adapt the file. Scale, crop, and rotate images. Apply custom tiling. And make colour corrections. All with controls that are at your fingertips.

- **Print directly from your creative applications or from Hot Folders that specify job properties**

This RIP supports up to two printers with multiple Hot Folders. Hot Folders are used to set up job properties. Either print directly from your creative applications or drag and drop jobs into the appropriate Hot Folder. When the program detects an available printer that matches the job properties, printing begins automatically. Using Hot Folders allows you to control job workflow and streamline job management.

- **Add cut marks to your print jobs easier than ever with this RIP's contour cutting workflow**

Take the manual process of adding cut marks to your print jobs out of your existing workflow and save time. Use the RIP's contour cutting workflow to define the cut paths in your print job. Cut marks automatically adjust when you scale, crop, and rotate images in the RIP's queue. You can even use barcode functionality to automatically scan preset cut paths. The RIP supports up to 10 cut layers (for bevelling, embossing, die-cuts, stickers, etc.)

Manage medias and calibrate your printer as needed

- **Use the RIP's default media calibration tables, or add and calibrate your own printing materials**

This RIP comes with a wide variety of default media calibration tables. Use them, or add and calibrate your own printing materials. As print conditions change, recalibrate your printer to your printing materials for best printing results. To get the look you want, use the included reference ICC profiles or import and apply custom ICC profiles, as well as create and edit density calibration tables and control ink restrictions.

Technical specifications

Print technology	Piezo-electric inkjet heads
Printhead nozzles	512 nozzles per head x 6 colours
Print resolution maximum	Print Resolution Black (best) up to 720 x 720 dpi, Print Resolution Color (best) up to 720 x 720 dpi
Number of inks	6 (Cyan, magenta, yellow, black, light cyan, light magenta)
Ink type	Low solvent pigmented inks
Ink drop size	12 pl
Ink cartridge size	1000 ml
Lightfastness	Three years without lamination
Print speed	Best: 8.17 m ² /h, colour image on vinyl media Normal: 16.35 m ² /h, colour image on vinyl media Fine draft: 20.4 m ² /h, colour image on vinyl media Draft: 29.9 m ² , colour image on vinyl media
Line	Line Accuracy ±0.3% or ± 5 mm whichever is larger
Memory	192 MB
Print margins (top x bottom x right x left)	Normal: 5 x 5 x 5 x 5 mm Using paper edge guard: 5 x 10 x 5 x 10 mm
Media types	Paper, vinyl, banner scrim, films, fabrics
Maximum media length	Roll: 50 m (RIP dependable)
Maximum media width	1626 mm
Maximum roll weight	24 kg
Media thickness	0.07 mm – 0.63 mm
Printhead height	2.1 to 2.6 mm
Media handling	Roll to roll printing, take-up reel with 4 winding positions, manual cutter
Interface and connectivity	Standard: USB 2.0 Hi-speed
Software	Onyx® PosterShop® 7.0 for HP Designjet (Optional (not included, sold separately) accessory on the HP Designjet 9000s Printer and HP Designjet 8000s Printer Series.)
Operating systems compatibility	For Onyx® PosterShop® 7.0 for HP Designjet: Windows 2000 Server with latest SP, Windows 2000 Professional with latest SP, Windows XP Professional SP2,
Minimum system requirements	For Onyx® PosterShop® 7.0 for HP Designjet: Windows 2000 Server (with latest SP), 2000 Professional (with latest SP), XP Professional SP2, Intel Pentium III/AMD Athlon 1.5 GHz or higher, 1 GB RAM per printer, 40 GB hard drive, 1280 x 768 16-bit color display, DVD-ROM drive
Recommended system requirements	For Onyx® PosterShop® 7.0 for HP Designjet: Windows 2000 Server (with latest SP), 2000 Professional (with latest SP), XP Professional SP2, Intel Pentium IV 2.5 GHz or higher, 1 GB RAM per printer, 120 GB Serial ATA hard drive, 1280 x 768 16-bit color display, DVD-ROM drive
Power	Requirements: Printer active: 200 watts Printer with Heater active: 1440 watts Printer standby: 40 watts Heater standby: 2 watts Printer: Input voltage 100 to 127 VAC (± 10%), 50/60 Hz ± 1 Hz, 2 amp; 220-240 VAC (± 10%), 50/60 Hz ± 1 Hz, 1 amp Heater: Input voltage 100 to 127 VAC (± 10%), 50/60 Hz ± 1 Hz, 12 amp; 220-240 VAC (± 10%), 50/60 Hz ± 1 Hz, 6 amp
Dimensions (w x d x h)	Out of package: 2540 x 861 x 1201 mm, packaged: 2720 x 1020 x 1420 mm
Weight	Out of package: 269 kg, packaged: 351 kg
Operating environment	Environmental ranges: Recommended operating temperature: 15 to 30° C, storage temperature: 5 to 35° C, operating humidity range: 30 to 70% RH, recommended humidity range: 30 to 70% RH, sound pressure, active: 60 dB (A), sound pressure, standby: 45 dB (A)
Certification	Safety certification: Compliant with IEC 60950, including EU LVD and EN60950, CSA certified for US and Canada, Mexico NYCE, Argentina IRAM, Singapore PSB, Russia VNIIS, Poland EL TEST Electromagnetic certification: Compliant with Class A requirements including EU (EMC Directive), USA (FCC rules), Canada (DoC), Australia (ACA), New Zealand (MoCo), Japan (VCCI), Korea (MIC), Taiwan (BSMI) Environmental certification: WEEE, ROHS
Warranty	Printer/printheads: one year warranty

Ordering information

Q6665A HP Designjet 9000s Printer, (with stand assembled), Waste Ink Bottle (2), Tension bar for take-up reel, Coated paper, Paper tube, Screwdriver for Assembly, Maintenance Kit, Ink cartridges (6), Exhaust Attachment Kit, Power Cord for Printer, Power Cord for Heater, User Guide CD, quick reference guide, USB Cable, rubber gloves

Accessories and software

Q6667A HP Designjet High Speed Dryer
Q6668E HP Designjet Air Purifier System
Q6669B Onyx® PosterShop® 7.0 for HP Designjet
Q6680A Media cover for HP Designjet 9000s series
Q6710A HP Designjet APS Filter

Media supplies

Q8678AE HP Premium Scrim Banner 470 g/m² – 36"/914 mm x 50 m
Q8679AE HP Premium Scrim Banner 470 g/m² – 54"/1372 mm x 30.5 m
Q8680AE HP Universal Scrim Banner 440 g/m² – 36"/914 mm x 50 m
Q8681AE HP Universal Scrim Banner 440 g/m² – 54"/1372 mm x 30.5 m
Q8682AE HP Premium Self-adhesive Vinyl 275 g/m² – 54"/1372 mm x 45.7 m
Q8683AE HP Premium Self-adhesive Vinyl 275 g/m² – 60"/1524 mm x 45.7 m
Q8684AE HP Premium Backlit Film 180 g/m² – 36"/914 mm x 20 m
Q8685AE HP Premium Backlit Film 180 g/m² – 54"/1372 mm x 20 m
Q8686AE HP Universal Photo-realistic Paper 195 g/m² – 36"/914 mm x 45.7 m
Q8687AE HP Universal Photo-realistic Paper 195 g/m² – 54"/1372 mm x 45.7 m

Ink supplies

CB271A HP 790 Black Ink Cartridge, 1000 ml
CB272A HP 790 Cyan Ink Cartridge, 1000 ml
CB273A HP 790 Magenta Ink Cartridge, 1000 ml
CB274A HP 790 Yellow Ink Cartridge, 1000 ml
CB275A HP 790 Light Ink Cartridge, 1000 ml
CB276A HP Light Magenta Ink Cartridge, 1000 ml
CB299A HP 790 Waste Ink Bottle
CB293A HP 790 Wiper Cleaning Kit
CB294A HP 790 Cap Cleaning Kit
CB296A HP 790 Ink System Cleaning Kit
CB297A HP 790 Ink System Storage Kit

Service & support

UD916A/E HP Care Pack, Next Business Day On Site, 3 years
UD922A/E HP Care Pack, 13x5 Same Business Day On site in 4 hours, 3 years
UD925PA/PE HP Care Pack, Post warranty, Next Business Day On Site, 1 year
UD927PA/PE HP Care Pack, Post warranty, 13x5 Same Business Day On Site in 4 hours, 1 year
UD917E HP Care Pack, Next Business Day On Site, 4 years
UD918E HP Care Pack, Next Business Day On Site, 5 years
UE698E Next Business Day Onsite w/1 Preventative Maintenance Kit per year, HW Support, 3 year

For a complete list of supplies, accessories and services, please refer to <http://www.hp.com/go/designjet>

<http://www.hp.com>
<http://www.hp.com/go/designjet>



©2007 Hewlett-Packard Development Company, L.P. The information contained herein is subject to change without notice. The only warranties for HP Products and services are set forth in the express warranty statements accompanying such products and services. Nothing herein should be construed as constituting an additional warranty. HP shall not be liable for technical or editorial errors or omissions contained herein.

Published in EMEA 03/07 4AA0-2371EEE

